



Dehumidifier ADP2000÷9500G

Technical manual

Unit 400Vac-3P-50Hz



Table of contents

General information governance and security concepts	4
Warranty.....	5
Copyright.....	5
Marking unit.....	6
Safety symbols used	6
Applications	7
Principle of operation	7
Product description	8
Structure.....	8
Rotor.....	8
<i>Drive system.....</i>	8
<i>Bearings</i>	8
Filters.....	8
Fans for the process and re generation air	8
Purging and energy recovery	9
Reactivation air pre-heater coil.....	9
Reactivation air heater coil	9
<i>Electric.....</i>	9
<i>Steam</i>	9
<i>Hot water</i>	9
Electrical panel	9
Possibility of operation.....	10
Installation	11
Equipment requirements and installation location	12
Connecting channel.....	12
<i>General instructions.....</i>	12
<i>Specification for the expulsion channel of moist air</i>	13
<i>Specifications for the input channel of reactivation air</i>	13
<i>Specifications for the channels of process air and dry air in case the dehumidifier is installed inside the room to be dehumidified</i>	13
<i>Specifications for the channels of process air and dry air in case the dehumidifier is installed outside the room to be dehumidified.....</i>	14
Connections of hot water coil for supplementary heating	15
<i>Installation.</i>	15
Steam connections	17
<i>Recommended installation.</i>	17
<i>Information about connections.....</i>	18
<i>Settings and testing.</i>	19
Gas burner	19
<i>Description.</i>	19
<i>Gas control unit.....</i>	20
<i>Low pressure switch (2).....</i>	21
<i>High pressure switch (1).....</i>	21
<i>Gas control valve module (V3).....</i>	21

<i>Burner safety control unit</i>	22
<i>Schedule light</i>	22
<i>Flame detection</i>	23
<i>Stop / Lock</i>	23
Electrical connections	23
First start-up	24
Preliminary checks	24
Adjustment of the gas burner	25
Adjusting the air flow	26
<i>General information</i>	26
<i>Airflow process</i>	26
<i>Reactivation airflow</i>	26
Control of the reactivation heating coil	27
<i>Hot water coil</i>	27
<i>Steam coil</i>	27
Maintenance	28
Safety	28
Filters	28
Rotor	28
Electric engines	28
Heating coil	29
Trasmission belt of the rotor	29
Seals	29
Overall summary service intervals	29
Inspection	30
Storage	30
Unpacking	30
Lifting and handling	31
Troubleshooting	32
Technical specifications	33
Technical data	33
Dimensions	34
Space required for installation	35
Electrical connections: Preliminary Information Security	36
Electrical data	36
HOW TO CONNECT THE POWER SUPPLY	37
Electrical wiring:	38
Description of Adjustment Control	Errore. Il segnalibro non è definito.
Display Description	Errore. Il segnalibro non è definito.
<i>Unit status Menu</i>	Errore. Il segnalibro non è definito.
<i>Set-Point Setup Menu</i>	Errore. Il segnalibro non è definito.
<i>Total hours of operation</i>	Errore. Il segnalibro non è definito.
<i>Factory Settings Menu</i>	Errore. Il segnalibro non è definito.
<i>Alarms Menu</i>	Errore. Il segnalibro non è definito.

General information governance and security concepts

- Anyone who uses the dehumidifier **AD** must have at his/her disposal this technical manual and know the security concepts written in this book.
- All the information described in this manual are only suggestions for the optimum use; they don't intended to replace personal responsibility and/or local safety regulations.
- Maintenance and malfunction must be performed only by authorized personnel.
- The installation of the controller and its electrical connection describe in the following, must be carried out by authorized personnel only. Repairs must be done by authorized personnel only.
- This dehumidifier must not be installed in explosion-endangered areas.
- The unit must not be immersed in water or constantly exposed to water spray.
- Do not insert anything such as fingers or branches into the air vents.
- The power supply is constantly present in the switch for the unit.
- Turn off input power before opening any panel of the dehumidifier.
- Allow the unit to cool down before maintenance work (at least 15 minutes after turning off).
- After power failure or mains disconnection, an automatic restart of the machine may take place after voltage return. So, turn off and padlocked always switch power OFF before any maintenance work.
- The panels of the dehumidifier must be removed only to perform maintenance.
- The dehumidifier can be installed only to dehumidify air at atmospheric pressure.
- Do not operate the unit without filters or when the filters are soiled.
- Never remove the labels or allow them to become obscure.
- Read this information and keep this manual accessible in the immediate vicinity of the dehumidifier.
- The monitoring operations and maintenance must be performed in strict accordance with the instructions.
- Not attempt to repair or maintain the dehumidifier and always contact TFT for any repairs or maintenance.
- Do not modify the unit without written authorization of TFT.
- During operation or other interventions on the machine, users have the responsibility to asses: the safety of everyone involved, the safety of the unit and other assets, the protection of the environment.

Warranty

- The warranty period is valid from the date on which the unit is out of the factory, unless otherwise specified in writing.
- The warranty is exclusively limited to the repair or replacement –free of charge- of parts which are acknowledged as defective by TFT due to defects in materials or manufacturing.
- All warranty claims with proof of defect must be received within the applicable warranty period for this warranty to be effective. Every claim must have the evidence that the unit is properly operated under conditions of normal use in accordance with applicable safety and regulatory requirements. All requests must specify the type of unit and the serial number. This information is printed on the rating plate, see the paragraph “Marking Unit”.
- Repairs or maintenance by non-qualified personnel will invalidate the warranty, as will the use of non-approved spare parts. In order for the warranty to be valid, the customer must scrupulously documented any repair and maintenance.
- TFT srl liability shall not include defects caused by inadequate maintenance or repairs or by incorrect installation by the Buyer, or else by alterations made without TFT’s written approval.

Conformity with directives

- The dehumidifier is in conformity with the essential safety requirements set the revised Machinery Directive 2006/42/EC, the Low Voltage Directive (LVD) 2006/95/EC, the ElectroMagnetic Compatibility Directive (EMC) 2004/108/CE e the RoHS Directive 2011/65/EU.
- The dehumidifier is produced by a company certificated ISO 9001:2008.

Copyright

- The contents of this document may be changed in the future, without prior notice.
- This manual contains proprietary information protected by copyright. It’s not allowed to copy and/or to reproduce in whole or in a part the content of this manual without the written authorization of TFT.

Marking unit

- The marking unit with ID and EC is located on the left side under the electrical panel, as shown in the figure below.

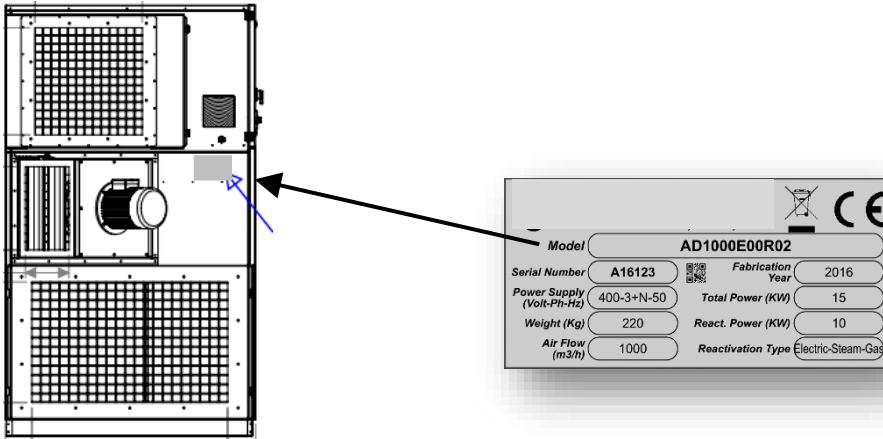

Safety symbols used



GENERIC DANGER

Observe all signs placed beside the pictogram. Failure to follow the warnings and instructions may result in several injury or death to the machine operator, a bystander, or a person inspection or repairing the machine.



ELECTRIC DANGER

Observe all signs placed beside the pictogram. The symbol indicates components of machine or, in this manual, actions that could generate a fulguration risk.



MOVING PARTS

This symbol identifies hazards associated with moving parts.



HOT SURFACES

This symbol identifies the presence of exposed hot surfaces that will cause serious burn injuries.



SHARP SURFACES

This symbol indicates that dangers may arise, for example, due to uneven surfaces, sharp edges, or the use of operating materials and adjuvants.



ELECTRICALPANEL AUTHORISED PERSONNEL ONLY

Operation, maintenance and/or repair of the electrical panel must only be carry out by personnel trained and qualified to work with electrical devices.



GROUNDING

This symbol identifies the grounding.



RECOVERABLE/RECYCLABLE MATERIAL

Applications

The dehumidifier **AD** is a desiccant dehumidifier, a rotary type using a humidity adsorbing rotor to dehumidify air at atmospheric pressure. It can be used to dehumidify air at relative humidity up to 100% and temperature from -30°C to +40°C.

There are so many applications and the following are some examples:

- Humidity control in production processes
- Drying of temperature-sensitive products
- Maintaining the proper level of humidity in the storage warehouses
- Corrosion protection of plants and in general of ferrous materials
- Humidity control in museums and libraries
- Drying properties after flooding and construction
- Improvement of the environment everywhere occurs excessive moisture

Principle of operation

This dehumidifier works in a continuous process with two air streams, process air and reactivation air. As shown in the figure, a honeycomb rotor dehumidifier consists of a honeycomb adsorbent rotor, which is rotated, in a casing at a low speed of around 8 rph by a geared motor in the outer circumferential drive method. The casing is divided into two sectors of process zone and re generation zone.

Process air is led in the process zone to contact the rotating honeycomb rotor. While it passes through the honeycomb channels, water vapor is adsorbed and it becomes dry air to be supplied. Sometimes later, the honeycomb rotor having got wet due to moisture adsorption enters the regeneration zone by rotation. The rotor is reactivation by hot air passing through honeycomb channel and turns again to the process zone. Dry air can always be produced in stable conditions by this continuous cycle. Process air is dried in the rotor between -30°C and +40°C, the re generation air is beaten by an internal coil up to about 100°C.

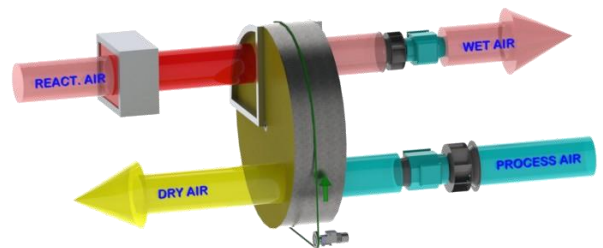

Product description

The dehumidifier is designed to meet the requirements of the degree of protection IP54 of IEC.

Structure

The structure is made with pre-painted double-shell galvanized/AISI 304 steel panels (sandwich type). The top panel can be removed for maintenance purpose. The connection to the dehumidifier can be made with standard gimped channels.

Rotor

The ceramic matrix is combined with synthesized silica gel to form the most advanced dehumidifier rotor. The ceramic matrix gives structural support for the thin layer of advanced silica gel. The synthesized advanced silica gel is self-bonding to the ceramic matrix and to itself through the matrix, filling in all the voids in the matrix and totally encapsulating the ceramic. Only the desiccant in contact with air-stream. The advanced form of silica gel has an extremely high "affinity" for water vapor. It has an active surface with numerous macro-pores of uniform size and shape. The many internal micro-pores quickly adsorb humidity and are readily de-sorbed for convenient and continuous dehumidification. The synergistic form of the desiccant and ceramic matrix allows for distinct advantages over both granular adsorbents and impregnated desiccants. With the advanced silica gel rotor there are no granules and no dusting. It stops adsorbing moisture when moisture is in equilibrium with the moisture in the passing or surrounding air-stream. There are never any deliquescent problems associated with this system. Furthermore, it can be coupled with a pre-cooling coil.

Drive system

A belt drive system controls the movement of the rotor. The strap exerts its traction on the outer edge of the rotor and is driven by a pulley on the motor reducer. A special device maintains the correct belt tension to prevent slippage of the belt. The correct direction of rotation and the transmission can be verified by opening the front panel.

Bearings

The rotor is provided with ball bearings. The rotor shaft is stainless steel.

Filters

The dehumidifier has two filters (G4) separate: one on the input process air and the other one on the input reactivation air. In option filters with different efficiency can be installed.

Fans for the process and regeneration air

The fans are directly coupled to a single-phase motor and/or three phase class IP55, ISO F, Class B. They are accessible for maintenance by removing the panel inspected. The fans can be controlled with a frequency converter for controlling the speed of rotation. The fan control process by default is set at a fixed speed, but it can be configured with variable speed and controlled by an external signal, or by a pressure sensor.

Purging and energy recovery

Bleeding and energy recovery are solutions aimed at energy saving, which recycle heat from the rotor or by recovering heat of the moist air expelled. This reduces the energy required for the heating coil of the regeneration air.

The “purge with a low dew point” is used to allow very low dew point. A marginal part of air-stream of dry air is mixed with the inlet reactivation air, making more efficient drying of the rotor.

Reactivation air pre-heater coil

The pre-heater coil is an additional coil to further reduce energy costs. Generally it is installed on the input of the reactivation air and consists of a heat exchanger (finned coil) and a control valve with a proportional actuator. It may use steam or hot water, coming from the centralized system.

During normal operation, this coil works as the main coil, whereas the electric heater coil comes into operation if the supply of heating becomes insufficient or it's request more dehumidification capacity. The control valve of the hot water or steam is factory assembled and supplied already connected to the unit.

Reactivation air heater coil

Electric

The reactivation electric coil has steel elements, connected in star and divided into 2,3 or more groups for the regulation in step with sequential insertion to have a modulation of the power. Optionally you can use a continual modulation with a proportion management of the power to increase the efficiency of the yield of the dehumidifier and save energy.

Steam

The reactivation steam coil consists of steel tubes aluminum fin (in option a stainless steel version or other material can be request), and includes a 2 way valve (supplied optionally) with a modulating actuator to ensure a greater efficiency of the dehumidifier, acting on the flow rate of the steam.

Hot water

The reactivation coil with hot water consists of copper tubes and aluminum fins (in option stainless steel or other material can be required), and it includes a 3-way valve (supplied as an option) with modulating actuator, to ensure greater efficiency of the dehumidifier, acting on the water flow. The coil is approved to the Pressure Equipment Directive (PED) for use in Europe with air and oxygen. If there is the risk that the temperature falls causing frosts, you must install and connect a sensor according to the wiring diagram. The sensor checks to see if the temperature is below the safety threshold, opening completely the valve to make the hot water circulate inside the exchanger. If the temperature continues to fall, an alarm will signal and the dehumidifier stops.



If there is the risk that the temperature falls causing frosts, we recommends adding the antifreeze in the water, to avoid damage to the heat exchanger.

Electrical panel

The electrical panel is located inside the unit. Switches and indicators of operation are located outside the dehumidifier.

Possibility of operation

The mode selector on the outside of the dehumidifier allows the following modes:

0 dehumidifier stopped

LOC Starting dehumidifier from local control

REM Dehumidifier starting from remote control



Dehumidifier in operation continuously (power 100%)



Dehumidifier controller by a humidistat or by an external signal



After the dehumidifier has been switched off, wait at least for 15 minutes before going inside in order to allow the dehumidifier to cool.

Installation

GENERAL INFORMATION AND USE OF SYMBOLS



Before performing any type of operation each operator must know perfectly the operation of the machine and its controls and must have read and understood the information contained in this manual.



All operations performed on the machine must be done by qualified staff in accordance with national legislation in force in the country of destination.



The installation and maintenance of the machine must be carried out according to national or local regulations.



Do not get close and do not insert any objects into moving parts.

WORKERS' HEALTH AND SAFETY



The operator's workplace must be kept clean, tidy and free from objects that might hinder movement. The workplace should be adequately illuminated for the work in. Insufficient or excessive lighting can generate risks.



Make sure work places are always adequately ventilated and suction system are always functional, in excellent condition and in compliance with the provisions of the law.

PERSONAL PROTECTION DEVICES



Operators engaged in the installation and maintenance of the machine must wear the appropriate personal protective equipment required by law and listed below.



Protective footwear.



Eye protection.



Protective gloves.



Respiratory protection.



Hearing protection.

Equipment requirements and installation location

The dehumidifier **AD** must be installed vertically inside a building fitted with a solid and level flooring and be fastened securely to the floor.

Leave a space of 1500 mm on the inspection able side of dehumidifier for maintenance, replacement of filters...

Connecting channel

The dehumidifier can be installed inside or outside the room, which is going to be dehumidified. To improve the performance of the installation is recommended to remove the flow from the air intake.

General instructions

The connections for the process air and the reactivation one are designed in accordance with ISO 13351. The connections of rectangular ducts contain inserts to secure the screws M8.

NOTE! The dehumidifier is designed for specific process air-flows, which correspond to the dimensions of the fans installed and must not be connected to existing air conditioning systems.

Upon installation of the network of ducts between the dehumidifier and the inlet and outlet connections for inlet and outlet, observe the following guidelines:

- The length of the network of ducts must be minimal in order to limit the pressure drops.
- For best performance, all stiff joints of process and reactivation air ducts must be sealed for air and steam.
- The process air duct must be isolated in order to avoid the formation of condensation on the outside, if the temperature inside the duct falls below the dew point of the ambient air.
- If there is a risk of sub-zero temperatures, the ducts must be insulated.
- The high rate of humidity of the air, issued by the unit, it could cause condensation of water inside the ducts. By insulating the ducts the amount of condensate decreases.
- The horizontal ducts of moist air must be installed with a slight slope (away from the dehumidifier) for the drainage of any condensate. In correspondence of the lowest points of the exhaust duct of the moist air devices shall be installed to drain the condensate. The moist air duct must be made of anticorrosive material (for example, stainless steel, aluminum, plastic, etc.) And it must withstand temperatures that can reach 100 °C.
- The ducts must be designed so as to prevent the infiltration of rain or snow in the dehumidifier.
- To reduce the transmission of vibration and/or noise along the rigid ducts, the installation of flexible watertight joints and any silencers is recommended.
- The ducts mounted directly on the dehumidifier must be equipped with suitable support to reduce the load and the voltage due to the weight and movement of the ducts themselves.
- You must install the manual dampers on the flows of the process and reactivation air, to maintain the functional efficiency of the unit
- The total pressure drop of the process and reactivation air ducts should not be higher than the available pressure of the fans.

Specification for the expulsion channel of moist air

The humid air from the dehumidifier must be expelled outside. The channels must be as short as possible to minimize the possibility of condensation of moist air within them. This channel should be slightly sloped to prevent any return of condensate inside the dehumidifier. If the channel of the moist air is very long or needs to be upwards, realize a drainage hole of 5 mm at the lowest point of the discharge channel. It must be installed an air flow regulation damper. Protect the channel output with a grid. If there is a risk that the temperature external to the conduit is very low, it is mandatory to insulate piping to prevent the formation of condensation inside the duct.

Horizontal
Expulsion

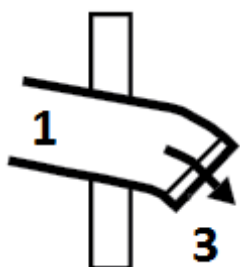

Vertical
Expulsion

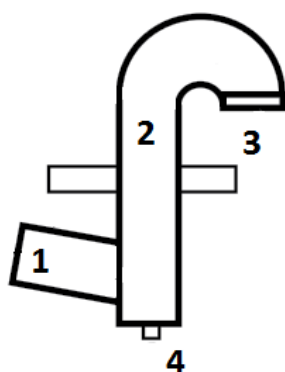

1. Slope down
2. Vertical expulsion of moist air
3. Wire mesh
4. Condensate drainage

Specifications for the input channel of reactivation air

This channel must be as short as possible. To prevent the entry of foreign bodies, protect the entrance channel with a grid. It is not necessary to isolate the pipe, which may be inclined downwards. In some installations, the reactivation air can be aspirated from the room where the dehumidifier is installed and in this case it is not necessary any channel.

It is advisable to install a damper on the reactivation circuit to allow a proper air flow calibration.

Specifications for the channels of process air and dry air in case the dehumidifier is installed inside the room to be dehumidified

In this case, it's not necessary the addition of aspiration channels for the process air; the installation of a protective grille is only required. The dry air produced must be ducted for the distribution inside the dehumidified room.

Specifications for the channels of process air and dry air in case the dehumidifier is installed outside the room to be dehumidified

In this case normally the inlet and outlet are channeled.

When the suction of air takes place from the outside, the outlet of the air duct must be at a sufficient height above ground level in order to prevent the suction of slag and dust. The air intake must be protected from possible contaminants, such as exhaust gas, vapor or harmful emissions. To prevent the ingress of moist air in the air intake of process or reactivation, the intake of the outside air must be positioned at least 2 meters from the exhaust duct of the moist air.

The ducts must be designed so as to prevent the infiltration of rain or snow in the dehumidifier. The dehumidifier aspires the dehumidified air by the environment or by a system of air pre-treatment (pre-cooling or pre-heating). The dry air produced can be sent to dehumidified environment or to a system of post-treatment.

A control damper can be installed to regulate the flow of dry air.

Connections of hot water coil for supplementary heating



CAUTION! The power supply lines of hot water must be designed and made by qualified personnel and in accordance with the legal provisions in force.



CAUTION! If there is a risk that the temperatures fall causing frosts, you must install a sensor to be used with the coil for frost protection. If there is a risk of freezing and not installed the sensor protection, the coil may be severely damaged.



CAUTION! If there is a risk that the temperatures fall, causing frost, it is advisable to install a damper on the input of the reactivation air with automatic closing in case of low temperature, to protect the coil. The damper is not included in the delivery.



NOTE! The hot water coil is adjusted for each delivery. For installation dimensions and/or space, refer to the specific design.



NOTE! Any additional control equipment required for compliance with local regulations are not included in the supply of TFT srl. For installation, refer to the documentation on the external equipment.

Installation.

The connections to the hot water coil are located outside the unit. The shut-off valves are not included in the standard delivery, but it is recommended to install them for easy maintenance and assistance.

Connection to the hot water coil:

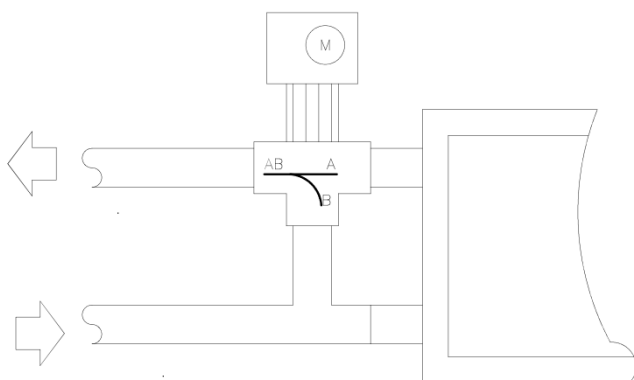

3-way valve:

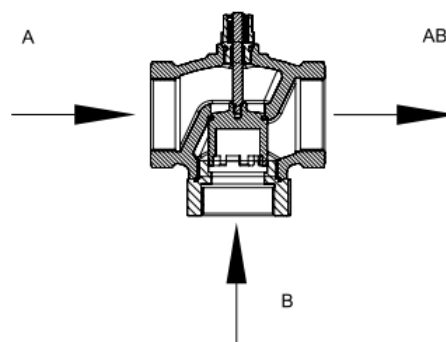



CAUTION! Avoid over tightening of connections, it may cause damage to the pipes of the coil.

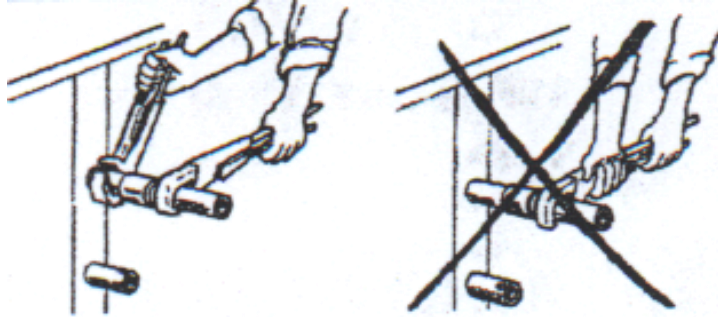

On this type of coil it is necessary to install a valve on the lower manifold to allow a complete drainage on the lower manifold and another one on the upper manifold for the air vent.

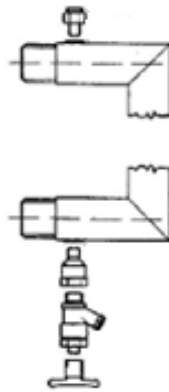

The normal heat exchange of a water coil occurs in counter.



Steam connections



- *Check that the stop valves are installed and closed before connecting the steam heating coil to a steam source.*
- *Ensure that the flanges are sealed and secured before connecting the steam heating coil to a steam source.*



CAUTION! The steam pipes must be connected by qualified personnel according to local regulations.



ATTENZIONE! The system must be designed so that the condensation of the steam is conveyed by gravity into an open condensate tank, which a vacuum breaker is installed in. This is very important for the life of the steam heating coil. Any condensate remaining within the heating coil will damage the unit the next time it is started.

Recommended installation.

It is necessary to install the following components as part of the circuit of the steam source so as to ensure a proper functioning of the system (see example figure below).

- A droplet separator for the removal of contaminants and fluids in the inlet steam. The separator removes fluids that may have a detrimental effect on the surface of heat transfer and also cause damage by erosion.
- To adjust the flow of steam through the heating coil is used a control valve of steam. For all types of control valves, it is important that they open slowly to reduce the risk of hydraulic shocks, thermal effects and erosion that can damage the heat exchanger. We recommend using a steam logarithmic control valve to slow the action of opening. The valve actuator must have an opening time of not less than 120 seconds.
- If a valve is used to control the modulation of the steam, keep in mind that the pressure drop in the valve affects the pressure of the steam to the heating coil and consequently on the temperature that can be achieved. Keep in mind this consideration when designing a control valve.
- You must install a vacuum breaker on the input in order to convey the steam condensation when the unit is shut down or used at low power.
- The condensate drain must be of type float, preferably with a integral thermal deaerator and a filter for dirt. You cannot use drains thermostats.
- In the line of the condensate return it is necessary to install a non-return valve to prevent the entry of the condensate in the heating battery and any malfunctioning of the condensate system. This measure is necessary when the line of the condensate return receives the condensate from the most drainages with different pressures and temperatures as well as to prevent a return flow when the level of condensate in the condensate tank increases.
- To compensate for the thermal expansion, it is required the presence of curves of expansion in the inlet and outlet tubes. All lines must be decompressed individually near the dehumidifier to reduce the load on the steam heating coil.
- In the event of a risk of freezing, it is necessary to install a thermostat immediately after the heating coil in the direction of airflow. If the temperature drops below +7°C, the thermostat detects a risk of freezing and therefore stops the dehumidifier unit so that the reactivation air flow is interrupted and an audible alarm starts to sound.

In addition to the above components, it is recommended to install the following components for easy operation and maintenance,

- A deaerator for the leakage of oxygen or other gases from the steam source.
- Shut-off valves.
- A manometer for measuring the pressure of the steam in the heating coil.
- A thermometer pressure resistant for indication of the temperature of the steam
- A filter for contaminants.

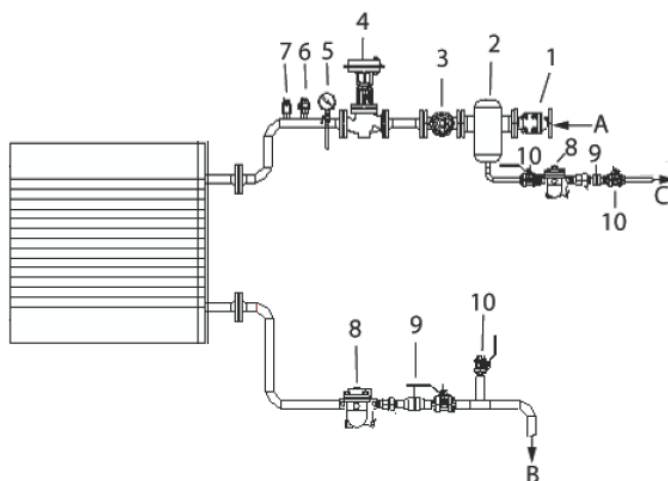

A. Steam source - **B.** Dehumidifier return - **C.** Drain condensate return

1. Filter steam
2. Droplet separator
3. Poppet valve
4. Steam valve
5. Manometer
6. Thermal deaerator
7. Vacuum breaker condensation
8. Condensate drain (body floating)
9. Modulation check valve
10. Ball valve (stop)

Information about connections.

Note the following considerations when connecting a source of steam to dehumidifier

- If a manometer is installed on the steam pipe, its measurement range cannot be less than the maximum pressure of the point at which it is installed.
- It is recommended to install an additional shut-off valves on the output of the heat exchanger after a drainage of condensation to facilitate the installation of a pressure gauge. This pressure gauge is used to quickly indicate any counter-pressure can occur in the condensate system in case of functional deviations during operation.

Settings and testing.

1. Check that the stop valves are closed.
2. Connect the heating coil to the steam source.
3. Open the stop valves.
4. Check that the pressure is shown in the pressure gauge correctly.
5. Make sure there are no leaks in the heating coil or in the tubes connected.
6. Check that the thermometer shows a temperature appropriate to the pressure in the pipe.

Gas burner



WARNING! All gas connections to the unit must be carried out by specialized personnel and in compliance with current regulations.



WARNING! The regeneration air must not be contaminated by combustible substances in the state of gas, vapor, fog or dust which, when mixed with air, create dangerous situations.



WARNING! The humid air outlet is the same as the exhaust of the combustion gases. For this reason it is essential to install the pipes in accordance with local regulations.

The gas supply pipes must be equipped with adequate supports to reduce the load and the tension due to their weight and movement.

The pressure at the inlet of the gas supply for the burner must be correct, see technical data section.

The regeneration air for the burner must be outside air (not recirculated) with a minimum oxygen content of 20%.

Only gas with a sulfur content of maximum 30 ppm (silicone gel rotor) should be used.

The correct type of gas is identified in the label next to the main identification plate, see technical data section.

Description.

Direct flame flammable gas burners are used on all dehumidifiers. The burner operates with natural gas or propane (optional) and employs the regeneration air which supplies the oxygen necessary for combustion. It is therefore essential to provide a flow of correct regeneration air to ensure that the burner operates efficiently.

For optimal performance, the air for regeneration must contain at least 20% oxygen. The air coming out of the burner can not be used. To keep the unit efficiency, it is also important that the humid air outlet is positioned correctly, in order to prevent the humid air from contaminating the regeneration air.

The burner is mounted in the flow of regeneration air. The gas is mixed with the regeneration air which penetrates into the space between the V-shaped mixing plates.

Behind the electrical panel, a spark ignition device and a flame detection probe are mounted near the burner's combustion chamber. The flame detection probe uses the ionization principle to send a flame signal to the burner safety control unit.

The operating principle with constant air flow and pressure drop in the burner ensures the correct mixing of combustion gases and regeneration air.

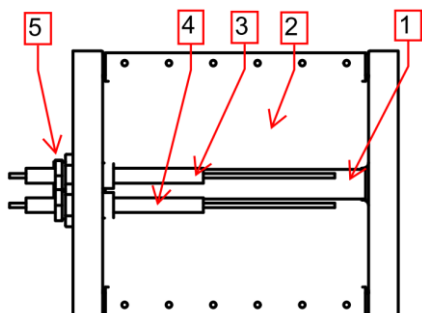

1. Gas burner head
2. Mixing plates
3. Spark ignition device
4. Flame detection electrode
5. Connection plugs

Gas control unit.

In the gas ramp there is a Gas control unit (gas ramp) that monitors and monitors the pressure and the flow of the gas. The gas train contains an adjustable flow regulator which in combination with an external control valve allows automatic modulation of the burner capacity.

The gas flows into the gas train, passes through the adjustable high pressure switch (1) and the low pressure switch (2). Valves V1 and V2 are energized by the same control signal and open at the same time. The pressure is set by the pressure regulator (V2). The maximum permitted gas flow (maximum burner capacity) is limited by the adjustable flow regulator supplied with the V2 valve. Regeneration power control is managed by flame control controlled by valve V3.

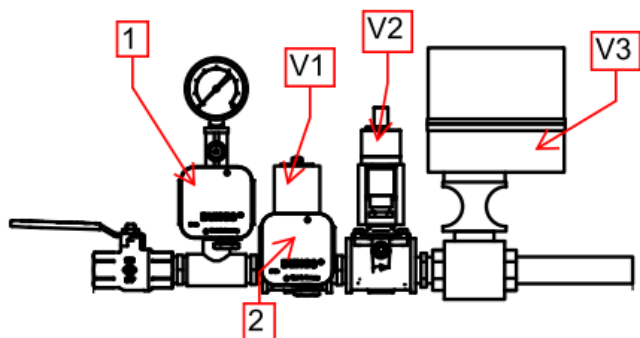

1. Maximum pressure switch
2. Minimum pressure switch
3. (V1) Valve for gas passage
4. (V2) Gas passage valve and pressure regulation
5. (V3) Proportional gas passage regulation valve

Low pressure switch (2).

The low pressure switch is connected to the inlet pipe in the gas train control unit. If the gas pressure is too low, the power supply to the control unit is interrupted. The dehumidifier is then switched off automatically, and a low gas pressure alarm is shown on the display of the burner control. The low pressure switch has a range of 2,5 to 50 mbar. The standard setting is 5 mbar.

High pressure switch (1).

The high pressure switch is connected to the inlet pipe in the gas train control unit. If the gas pressure is too high, the power supply to the control unit is interrupted. The dehumidifier is then switched off automatically, and a high gas pressure alarm is shown on the display of the burner control. The high pressure switch has a range of 30 to 150 mbar. The standard setting is 30 mbar.

Gas control valve module (V3).

This modulating regeneration air gas heating system includes a control valve installed in the gas line, on the gas train line, and the gas burner. This makes it possible to vary the gas flow and burner capacity during operation. The control valve is connected to an electric actuator that is controlled by the program module by means of a 3-point signal, proportionally.

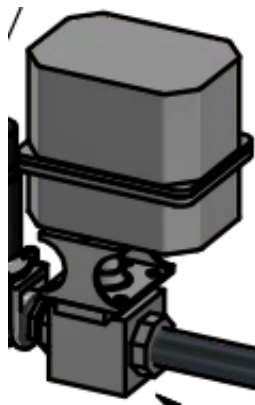

Burner safety control unit.

The control unit ensures safe ignition, start-up and shutdown both during normal operation and in the event of a fault. This is equipped with a self-diagnostic flux monitoring circuit that controls the combustion process. The flame monitoring circuit applies the necessary safety measures if the flame signal is activated too early or not activated at all, and if any type of fault occurs in the flame detector, in the detector cables or in the signal flame.

Faults that are detected during the start-up procedure or normal operation cause the shutdown. Operation is therefore prevented until the fault is cleared and the burner control unit is reset by resetting the alarm.



When the relay is powered and the start contact is closed, the burner control unit moves to the "start" position. When the burner control unit receives a start signal from the PLC, an automatic check is performed between the burner control unit and the regenerative airflow pressure switch. This is to ensure that a flow of air is present in the combustion chamber before starting the flame.

If after contacting the fan, the pressure switch contact does not close (in the "no air" position), the control unit will not start.

Immediately after the regeneration air fan is started, the burner control unit checks whether the pressure switch contact closes (the supply of combustion air is available).

If the contact has not closed, the control unit stops the burner start-up.

When the flow switch contact is closed, the discharge period begins. For about 30 seconds, all remaining gases are purged from the combustion chamber. Once the exhaust period is over, the ignition is switched on. After a few seconds the gas supply valves (V1 and V2) receive the power supply. If a flame has been lit and the flame has been detected by the probe, the relay will continue to operate until it reaches its ignition position. If no flame is present or it is not detected, the relay generates a burner lock, closing (V1 and V2) immediately. The program light stops at the position where the problem occurred as an aid in troubleshooting.

Schedule light.

The program light shows the status of the burner. Since the program light remains in the position where the shutdown occurs, this provides useful information that facilitates troubleshooting. The various situations that cause stopping are indicated by the following symbols:

-
- 01** Burner flame signal:
Value range: 0–25 μ A.
- 02** Burner switch-off threshold
(not on BCU 370..U1):
Value range: 1–20 μ A.
- 03** Last fault signal.
- 04** Air monitoring during pre-purge:
0 = No monitoring,
1 = Monitoring.
- 05** Air monitoring during operation:
0 = No monitoring,
1 = Monitoring.
- 06** Pre-purge:
0 = Quick start,
1 = On each start-up.
- 07** Burner start-up attempts:
1 = One start-up attempt,
2 = Two start-up attempts,
3 = Three start-up attempts,
4 = Four start-up attempts.
- 08** Behaviour in the event of flame failure during operation:
0 = Fault lock-out,
1 = Restart.
- 09** Safety time during operation t_{SB}
(1, 2 s).

Flame detection.

To verify the presence of a flame, a flame detection probe is used. The flame detection probe consists of a metal electrode located on the flame. The burner control unit detects the existence or absence and condition of the flame during start-up and normal operation. A flame failure always causes the burner to stop and stop.

Stop / Lock

When a shutdown / shutdown occurs, the cause must be resolved before the burner can be restarted using the reset button on the display. The stop / block can be due to the following:

- The low pressure switch on the gas train is faulty or incorrectly set.
- The regeneration air pressure switch is faulty or incorrectly set.
- The gas valves do not open.
- No ignition.
- Defect in the regeneration air fan.
- Flame failure (at start or during normal operation).

Electrical connections

In this regard, see the attached wiring diagrams.

First start-up

Preliminary checks



CAUTION! The installation and initial start-up of the unit must only be carried out by authorized personnel.



CAUTION! The power supply is constantly present in the general switch of the unit. Risk of electric shock.

For the first start-up, perform the following checks:

1. Make sure the power switch electrically isolates the dehumidifier and the isolator is in the OFF position.
2. Open the panels of the dryer and make sure there are no foreign objects inside and in the electrical cabinet.
3. Ensure that the flow control dampers are fully open and that the pipes are clean and unobstructed by objects.
4. Check the filters and check that they are clean.
5. Make sure that the fan impellers can move freely.
6. Ensure that the fuses are properly sized.
7. Electrically connect the dehumidifier to the electricity grid through the general switch and switch the main switch ON and check for the voltage at the terminal L, N or L1, L2, L3 of the dehumidifier.
8. Verify that the power supply has the correct phase sequence, using the control unit inside the power cabinet. The yellow LED must be switched on. If the yellow LED is off, change the general power phases (See image below).
9. The dehumidifier is ready to be used.
10. Start the dehumidifier and control the flow rate of the process and reactivation air. Check the flow rates on their respective sides of the air delivery. If it is requested, adjust the air flow through a damper installed on the flow of dry and moist air, or act on the adjustment of the frequency converter.
11. If it is requested, verify the performance of the dehumidifier by measuring the quality of the dry air produced on the output of the dehumidifier and compare the values with ones reported on p. 23.

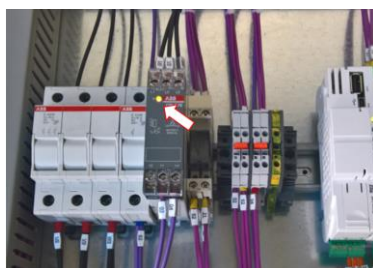
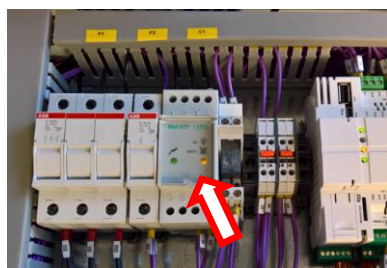

Adjustment of the gas burner



CAUTION! The burner and the metal parts surrounding it can become very hot. Be careful not to burn yourself.

1. Unscrew the burner observation glass cover.
2. Verify that the gas supply to the dehumidifier is switched on.
3. Open the gas supply valve.
4. Measure the supply pressure of the gas using the pressure gauge at the inlet of the gas train, pressure must not exceed the maximum allowed value. The pressure must be between 20 and 30 mbar.



NOTE! If the gas supply pressure exceeds 30 mbar, a reduction valve must be inserted in the gas suction line.

5. Verify that the low pressure switch is set to 5 mbar. If necessary, set the pressure using the setting wheel.
6. Verify that there are no leaks in the gas ramp leading to the burner.
7. Set the differential pressure on the regulating airflow pressure switch to 50Pa. This operation serves to avoid disconnection of the automatic burner device during air flow regulation.
8. Set the main switch to position 1 or ON.
9. Start the unit by setting the mode in the MAN position (100%) on the display.
10. Verify that the rotor turns in the direction indicated by the arrows. If the rotation direction is the wrong one, exchange the connections of the incoming cables in the general switch.
11. Adjust the gas pressure using the control valve (V2), which must be at 15/20 mbar. To adjust the working pressure, close the whole valve (V2) using the screw on the head (15), and open 2 turns (the units are already calibrated at the factory with a pressure of 20mBar) and check the flame status, which must not reach the wall of the dehumidifier.

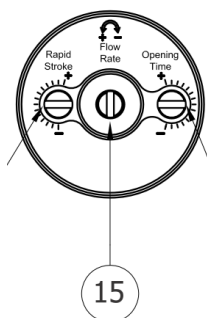

WARNING! All starting operations of these gas units must be carried out by qualified personnel, suitable for operating on this type of equipment. Incorrect regulation of the gas pressure causes malfunctioning in the system and damage to the dehumidifier (burning, overheating of components, risk of flammability, etc.).

Adjusting the air flow

General information.

For optimal performance, you must adjust the flow of process and reactivation air as a function of nominal air flows. You can set the airflows in the display of the control system without using dampers, if there are frequency converters inside the electrical panel.

Contact TFT for advice on installation and settings.



NOTE! Software settings and frequency converters are configured at the factory. The control range of frequencies is limited so as to correspond to an acceptable speed fan acceptable.



CAUTION! Danger due to rotation - to prevent access to the rotor of the fan, the dehumidifier must operate exclusively with wet and dry air ducts connected, or an appropriate safety equipment -such as protective grilles- must be installed



CAUTION! If airflows are not adjusted properly, a malfunction of the unit could happen. Damage to the unit due to a wrong adjustment of airflows could void the warranty of the unit.

The airflows should never be set to values higher than the nominal air flow. If you need higher air flow, contact TFT.

Airflow process

Follow the instructions listed below, to regulate the flow of process air.

Control of the process air fan at a fixed speed by ΔP

1. Start the dehumidifier and made it run at full speed.
2. Connect a differential manometer between the process air inlet (+) and the process air output (-).
3. Compare the measured differential pressure with the calculated value of the factory.
4. Adjust the control point of the process airflow in the control system acting on the frequency converter or through the damper, so that the differential pressure value measured corresponds to the calculated value of the factory.

Control of the process air fan at a fixed speed by airflow

1. Start the dehumidifier and made it run at full speed.
2. Measure the airflow of a duct section by a linear anemometer.
3. Compare the measured air flow rate with the nominal one.
4. Adjust the control point of the air flow in the process control system acting on the frequency converter or through the damper, so that the value of the air flow rate measured corresponds to the nominal value.

Reactivation airflow.

Follow the instructions listed below, to regulate the flow of the regeneration air.

1. Start the dehumidifier and make it run at full capacity for at least 10-15 minutes to allow the heater of the regeneration air to reach the normal operating temperature.
2. Measure and record the temperature in the input reactivation air intakes.
3. Read the temperature of the reactivation air in the display of the control system. The difference between the temperature of the reactivation air and the inlet temperature of the reactivation air must be about 95°C (with a tolerance threshold $\pm 5^\circ\text{C}$).

4. If the temperature difference exceeds the threshold of tolerance $\pm 5^{\circ}\text{C}$, adjust the setting of the fan of the reactivation air in the control system, acting on the frequency converter or through the damper. Wait until the temperature display has stabilized after each adjustment.

Control of the reactivation heating coil

Hot water coil.

1. Make sure that the stop valves are closed.
2. Connect the heating coil of reactivation air to the water distribution system.
3. Open the valve for the water supply.
4. De aerate all remaining air from the coil and the piping system.
5. Check that the water flows into the coil, sensing with a hand that the coil and the pipes heat up evenly.
6. Check the operation of the control valve.

Steam coil.

1. Check that the stop valves are installed and closed.
2. Connect the preliminary heating coil of the regeneration air to the steam source.
3. Open the valves to supply steam.
4. Read the pressure gauge and check that the pressure of the steam supply is correct.
5. Visually inspect the pipes connections and preliminary heating coil of the regeneration air and check for leaks.
6. Read the steam temperature on the thermometer and make sure the temperature is correct with respect to the line pressure.
7. Open the control valve manually, very slowly to test the system of the condensate drain line.

Maintenance

Safety



CAUTION! The installation, adjustment, maintenance and any repairs must be carried out by qualified personnel informed of the risks related to the operations of equipment supplied from high voltage and high temperature.



CAUTION! The power supply is constantly present in the switch for the unit. Risk of electric shock.



CAUTION! After a power failure the dehumidifier may restart automatically. Turn off the main switch and always padlocked supply before performing any maintenance work.



PLEASE NOTE! For any maintenance or repair:



- **Wait 15 minutes after turning off the dryer before opening any service panel, in order to allow for the cooling of the reactivation coil.**
- **Electrically disconnect the dehumidifier via the main switch.**
- **Disconnect the power plug**

The maintenance intervals depend on the environment which the dehumidifier is installed in. The frequency of these intervals may differ from one installation to another. Improper maintenance can result in decreased performance.

Filters

The dehumidifier is equipped with two separate filters, one for the process air and one for the reactivation air. The filters are placed on the inputs airflows of the dehumidifier. Cleaning or filter replacement intervals will be determined by the amount of dust and air particles where you installed the dehumidifier.

The filters should be checked at least once a month.

The unit can be equipped with the differential pressure gauges to check the pressure drop through the filters. Do not leave the dehumidifier in operation without the filters: the rotor could be ruined.

Rotor

The rotor doesn't need maintenance. However you may need to clean it very delicately with compressed air. If it is very dirty, the rotor can be washed with water but before you do this, contact your local distributor because it is not a routine operation. Check once a year the bearings and the surface of the rotor.

Electric engines

The electric engines are equipped with ball bearings. Maintenance operations of the bearings aren't necessary. Check the engine and any noise once a year.

Heating coil

Requires no maintenance. Check at least twice a year for any possible mechanical damage and clean the finned pack, controlling that the air flow is not obstructed by dirt or other material

Transmission belt of the rotor

Check at regular intervals the correct belt tension. It is kept under tension by the tensioning device and requires no adjustments during normal operation.

Seals

Check seals regularly for any damage or dust.

Overall summary service intervals

	Filters	Efficiency of the rotor	Engines	Belt of the rotor	Coil	Seal
When it is necessary	✓					
Every 6 months				✓	✓	✓
Every 12 months		✓	✓			



NOTE! Always contact TFT for service and repairs. Operational failures can occur if machine maintenance is carried out so insufficient, inadequate or incorrect.



NOTE! The inspection of installation/start-up performed by TFT is required to validate the full warranty.

Inspection

During installation or when you need to work on the unit, you must strictly follow the rules reported on this manual, follow the instructions on the unit and take any necessary precautions. Failure to follow the instructions set can cause dangerous situations. After receiving the unit, verify the completeness of the dryer: the unit left the factory in perfect condition; any damage must be immediately reported to the carrier and recorded on the Delivery Note before signing it. The Company must be informed the extent of the damage within 8 days. The Customer must prepare a written statement of any severe damage.

Before accepting delivery, please check that:

- the machine has not been damaged during transport;
- the machine is the same as specified in the transport document

In case of damage or abnormalities:

- note immediately damage on the delivery page;
- inform the supplier of the extent of the damage, within 8 days of receipt. Reports after this deadline are not valid ;
- in the event of substantial damage prepare a written statement.

Storage

If you need to store the unit, leave it packed in a closed place. If for some reason the unit was already unpacked follow these guidelines to prevent damage, corrosion and/or deterioration:

- Make sure that all openings are securely closed or sealed;
- To clean the unit, never use steam or other cleaning agents that could damage it;
- Take away and leave to the site manager any keys providing access to the control panel.

Unpacking



The packaging may be dangerous for operators.

It is advisable to leave the unit packed during handling and unpacking only at installation. The packaging unit has to be removed with care to avoid causing damage to the machine. The materials of the packaging may be of a different nature (wood, cardboard, nylon etc.)..



Packaging materials should be stored separately and delivered for disposal or possible recycling in order to reduce any impact on the environment.

Lifting and handling

When unloading the unit, it is highly recommended to avoid abrupt or violent movements to protect the inside. The units can be moved by forklift truck or an overhead crane, being careful not to damage the lateral panels and the cover. In the case of handling by forklift truck, put a spacer between the security structure of the unit and the forks of the lift, to avoid damaging to the panels. In the case of handling with a crane, we recommend using an adequate sling as a precaution, to prevent damage to the structure and internal components. The unit must always be kept horizontal during these operations.

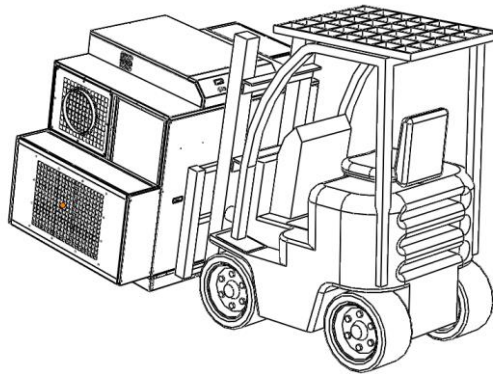

CAUTION! The dehumidifier weights over 100kg. To avoid personal injury or unit, always use approved equipment.

Troubleshooting

Sympton	Possible causes	How to act
Reducing dehumidification capacity	clogged filters obstructed steam coil steam valve doesn't open lack of steam flow reduced air flow rates the rotor is stationary internal air leaks insufficient reactivation air air leaks	clean or replace the filters check the reactivation coil verify the correct operation of the valve check the operating pressure of the steam, the adduction valves, the condensate drain check the dampers check the belt tension check the seals check the reactivation coil check the seals and the panels
Burned main fuses	malfunctioning of fans airflow is too high the rotor is stationary malfunction of reactivation coil	check fans and motors check the flow rates and the dampers check the engine and the belt check the reactivation coil
The dehumidifier will not start	control circuit control signal the power supply phases fuses for control malfunction	check the fuses check the external signal to start-stop check the main fuses and the phase sequence check the electrical components
The rotor is stationary	slippage of the belt broken belt off-axis rotor malfunction of the gear motor	check tension replace the belt check the position of the rotor on the central support replace the gear motor
Low process or reactivation airflow	clogged filers malfunctioning fans phases of electrical power the ducts are blocked	clean or replace the filters check the fan motors and impellers check the main fuses and the phase sequence control dampers and pipelines

Technical specifications

Technical data

TECHNICAL DATA							
MODEL	ADP	2000	3500	5000	6500	8000	9500
Performances							
Dehumidification Capacity *	Kg/h	15,7	28,4	40,3	53,2	61,5	72,4
Fans							
Process air flow	m ³ /h	2000	3500	5000	6500	8000	9500
Static pressure	Pa	400	400	400	400	400	400
Fan nominal power	KW	1,1	1,5	2,2	4	5,5	7,5
Reactivation air flow	m ³ /h	700	1200	1700	2200	2600	3100
Static pressure	Pa	400	400	400	400	400	400
Fan nominal power	KW	0,75	0,75	1,1	1,5	1,5	2,2
Drive Motor							
Nominal power	W	10	10	10	10	10	10
Regeneration							
Regeneration type		Gas	Gas	Gas	Gas	Gas	Gas
Installed power	KW	30	40	60	75	90	110
Natural gas (G20/G25)	mBar	18÷49	18÷49	18÷49	18÷49	18÷49	18÷49
Gas consumption (****)	m ³ /h	2,95	3,94	5,91	7,38	8,86	10,83
Temperature rise in the heating coil	°C	100	100	100	100	100	100
Electrical characteristics							
Power supply	Volt/Ph/Hz	400/3/50	400/3/50	400/3/50	400/3/50	400/3/50	400/3/50
Maximum power absorbed standard units	KW	2,1	2,5	3,6	5,8	7,3	10,0
Maximum current absorbed standard units	A	5,6	6,6	8,5	13,0	16,0	21,7
Noise level							
Sound pressure **	dB (A)	60	64	65	66	69	70
Sound power **	dB (A)	88	92	93	94	97	98

(*) With inlet air at 20°C 60%

(**) Sound pressure level calculated in free field, 10 meters from the unit, directional factor Q = 2 according to ISO 9614.

(***) Electrical protection standard, resistant to water and dust.

(****) 1 Nm³/h natural gas = 10,16KW

Dimensions

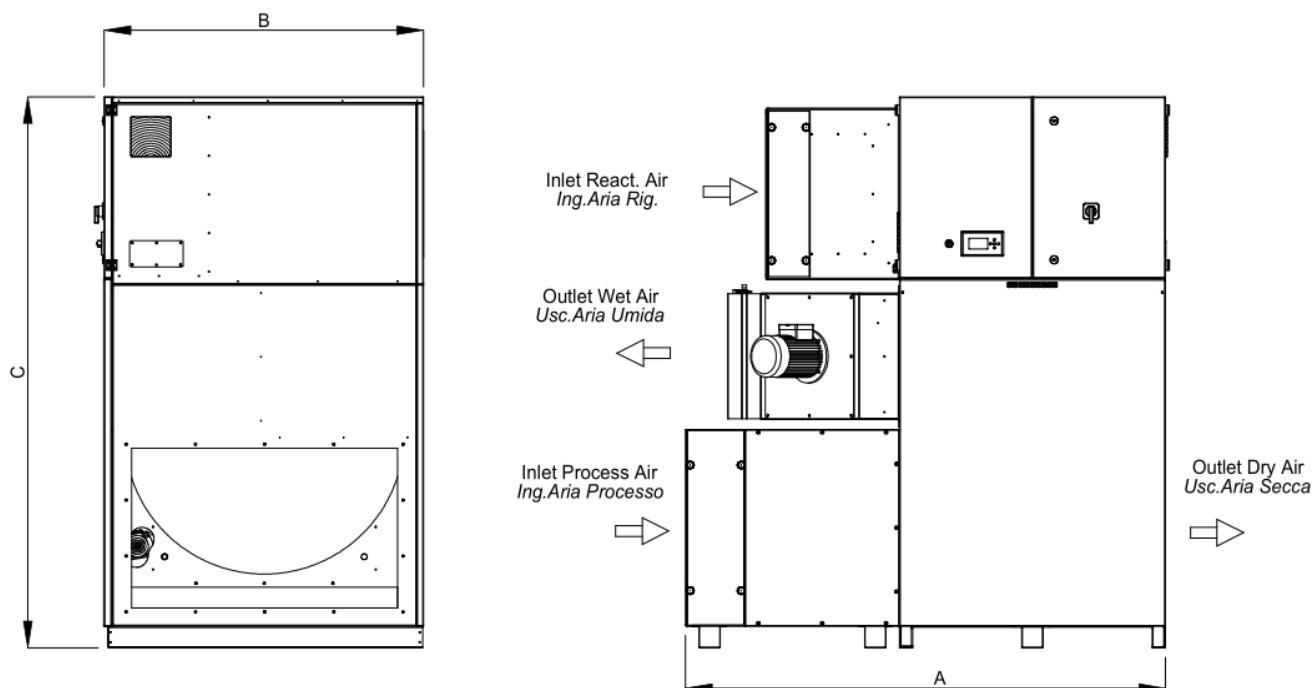

Model	AD	2000	3500	5000	6500	8000	9500
A	mm	1610	1710	1710	1810	1810	1810
B	mm	1000	1100	1100	1200	1200	1200
C	mm	1875	1975	1975	2075	2075	2075
Empty weight	Kg	490	550	590	690	710	730
Connections							
Process air inlet	mm	850 x 500	950 x 600	950 x 600	1000 x 600	1000 x 600	1000 x 600
Dry air outlet	mm	850 x 500	950 x 600	950 x 600	1000 x 600	1000 x 600	1000 x 600
Reactivation air inlet	mm	600 x 400	600 x 400	600 x 400	600 x 400	600 x 400	600 x 400
Wet air outlet	mm	370 x 200	370 x 200	370 x 200	370 x 200	370 x 200	370 x 200

Space required for installation

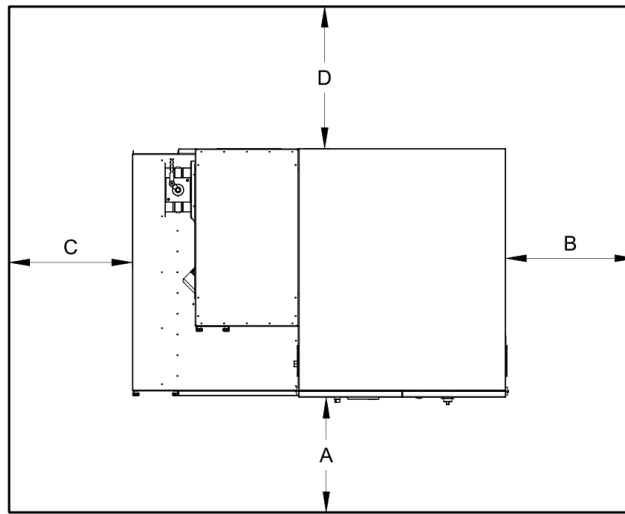

Model	AD	2000	3500	5000	6500	8000	9500
A	mm	1000	1100	1100	1300	1300	1300
B	mm	600	600	600	600	600	600
C	mm	600	600	600	600	600	600
D	mm	800	800	800	800	800	800

Access space recommended for installation and maintenance.

Electrical connections: Preliminary Information Security

The electrical panel is located inside the unit at the top of the technical compartment where there are also the components of the cooling circuit. To access the electrical panel, remove the top panel of the unit and the panel of the compressor compartment.



The connection must be made by a qualified electrician using wiring diagram provided with the machine, or according to local regulations and international standards.



Make sure that the power supply line of the unit is sectioned upstream of the unit itself. Make sure that the disconnecting device is padlocked or that the appropriate “not to operate” warning sign is applied to the operating handle.



Verify that the power supply corresponds to the nominal data of the machine (voltage, phases, frequency) reported on the wiring diagram and the rating plate attached to the unit.



The power cables must be protected upstream against the effects of short-circuit and overload by an appropriate device complies with regulations and laws.



The section of the cables must be commensurate with the calibration of the “upstream protection” system and must consider all the factors that may influence it (temperature, type of insulation, length, etc.).



The power supply must comply with the limits shown: otherwise, any guarantee will terminate immediately.



Make all ground connections required by the regulations and legislation.



Before carrying out any operation, ensure that supply voltage are disconnected.

Electrical data



The electrical data below refer to the standard unit without accessories. In all other cases, refer to the data reported in the electrical circuit diagrams.



The supply voltage must be within $\pm 10\%$ of the nominal value and the imbalance between phases must be less than 1% according to EN 60204. If those tolerances should not be respected, please contact our technical department.

The electrical data can change without notice. It is therefore necessary to refer always to the wiring diagram supplied with the unit.

HOW TO CONNECT THE POWER SUPPLY

To supply electrical power to units AD... remove the top panel; use the special cable in the rear or side panel and connect the power cord to the terminal block in the control cabinet.







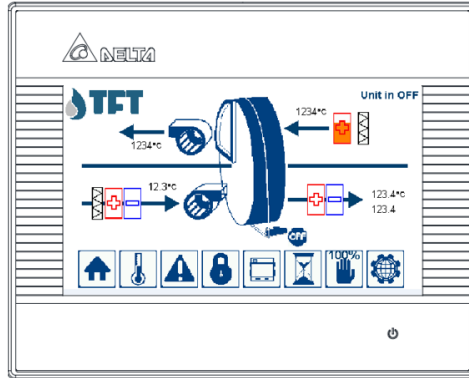

After connecting, carefully close the top panel.

Electrical wiring:

See attached diagrams

Description of Adjustment Control



	Go to Home Page.
	Main Set-Point Settings (User).
	Active alarms and historical alarms display.
	Super user or Factory settings.
	Unit status menu.
	Working time display (Service).
	Set the regeneration control mode to manual [100%] or automatic [AUTO].
	Program information and language change.

Display Description

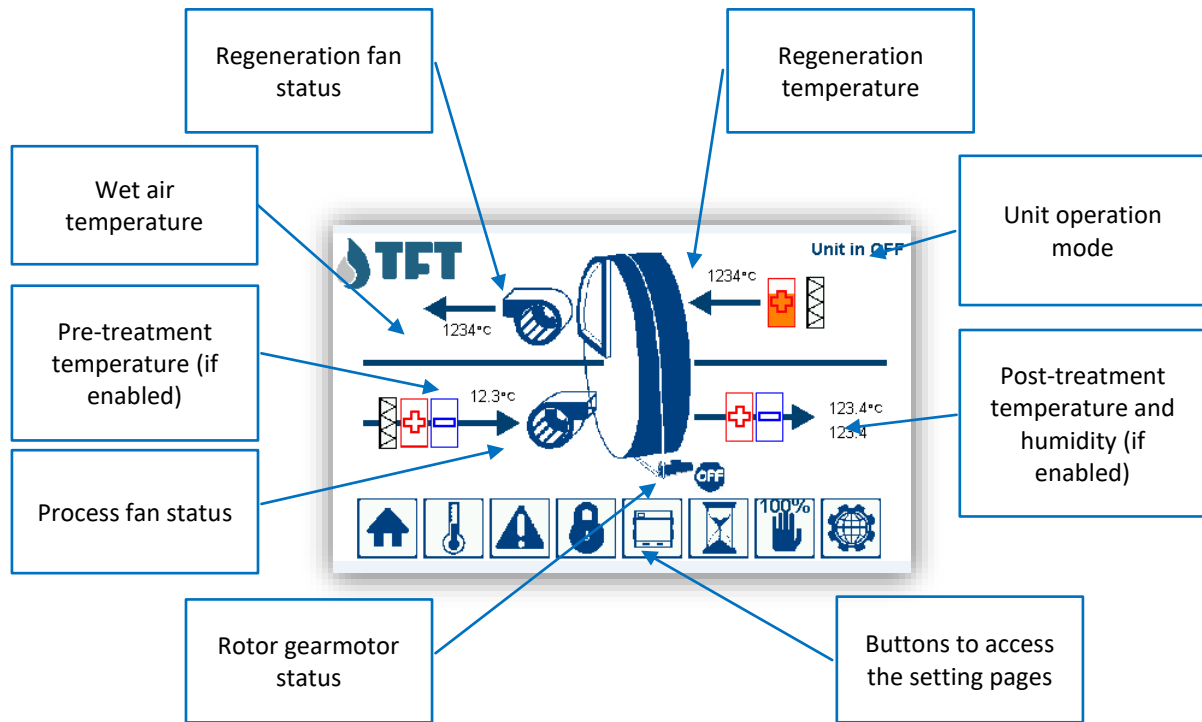

Press on the "buttons" to access the page you want.

Unit status Menu.

Regeneration:

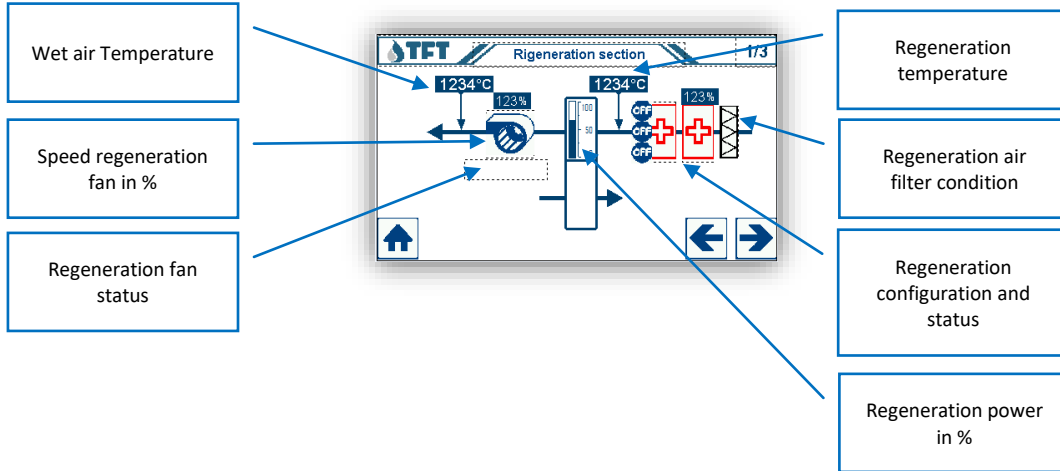

Air pre-treatment:

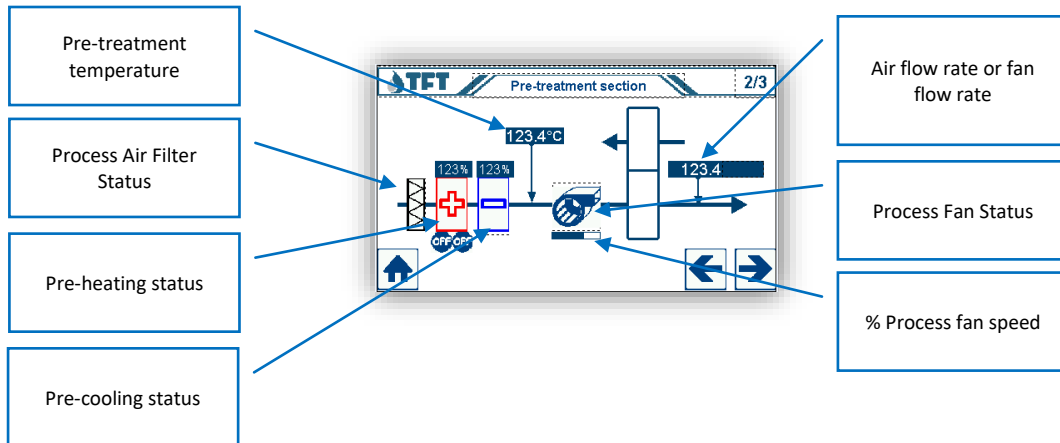

Air post-treatment:

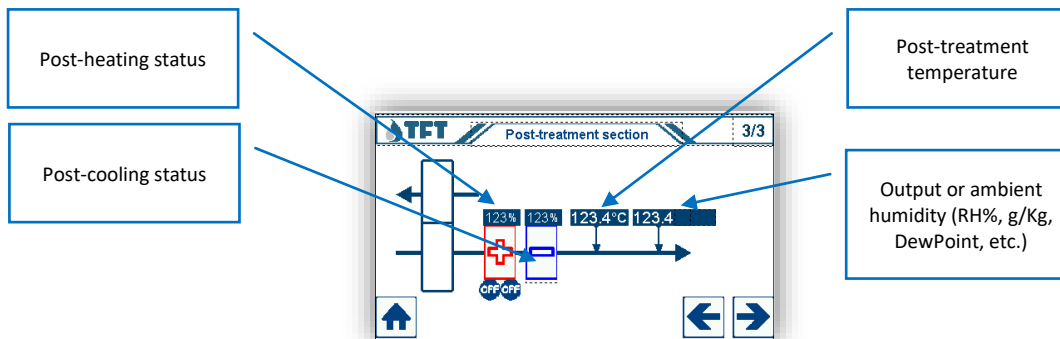

Set-Point Setup Menu.

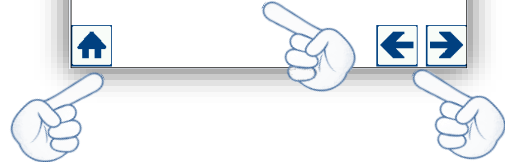
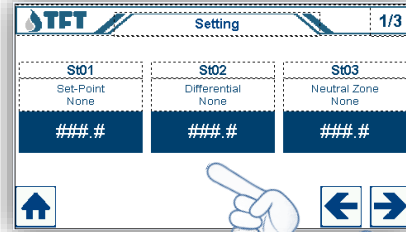
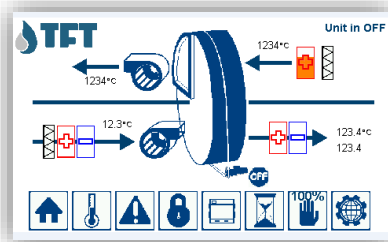

Scroll through the pages with the arrow keys to display the various setting pages, and press the value to edit to change the setting. To return to the main menu, press the key .

Total hours of operation.

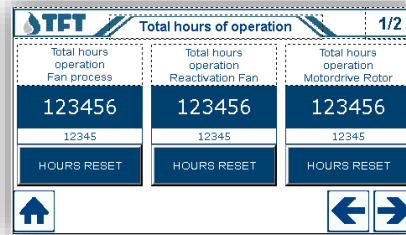
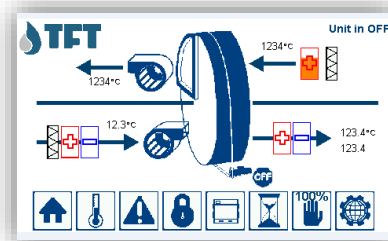

Scroll through the pages with the arrow keys to display the various pages. To return to the main menu, press the key .

Factory Settings Menu.

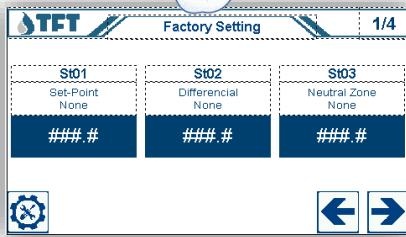
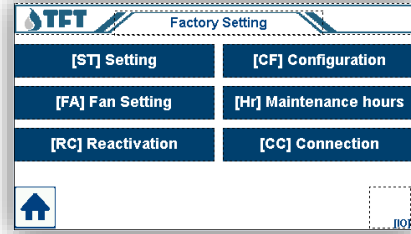
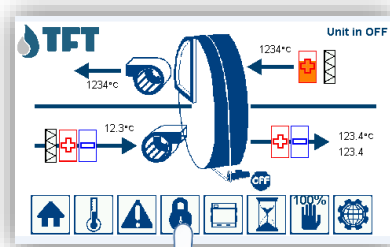

Parameter setting “St” (Set-point)

Scroll through the parameters with the arrow keys , to change the setting, press the number to change, a keypad will appear to enter the desired value, confirm the value set with the [ENTER] key. To return to the settings menu, press the key .

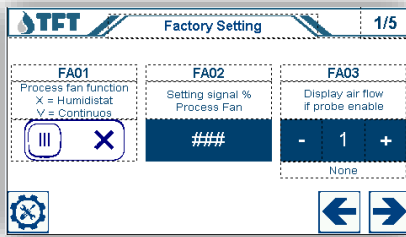

Parameter setting “FA” (Fans)

Scroll through the parameters with the arrow keys , to change the setting, press the number to change, a keypad will appear to enter the desired value, confirm the value set with the [ENTER] key. To return to the settings menu, press the key .

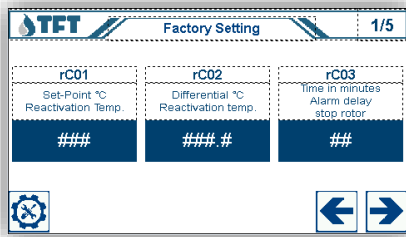

Parameter setting “rC” (Regeneration)

Scroll through the parameters with the arrow keys , to change the setting, press the number to change, a keypad will appear to enter the desired value, confirm the value set with the [ENTER] key. To return to the settings menu, press the key .

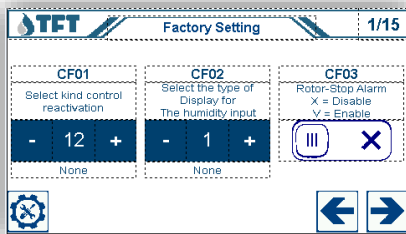

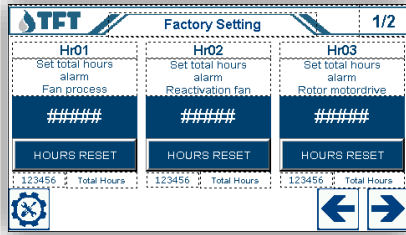

Parameter setting “CF” (Unit configuration)

Scroll through the parameters with the arrow keys , to change the setting, press the number to change, a keypad will appear to enter the desired value, confirm the value set with the [ENTER] key. To return to the settings menu, press the key .



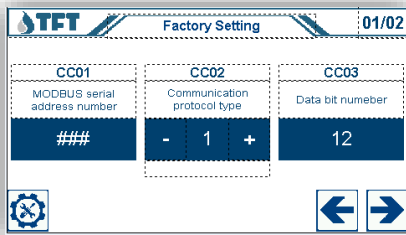

Parameter setting “Hr” (operating hours)

Scroll through the parameters with the arrow keys  , to change the setting, press the number to change, a keypad will appear to enter the desired value, confirm the value set with the [ENTER] key. To return to the settings menu, press the key .



Parameter setting “CC” (Communication ModBus)

Scroll through the parameters with the arrow keys  , to change the setting, press the number to change, a keypad will appear to enter the desired value, confirm the value set with the [ENTER] key. To return to the settings menu, press the key .

USER AND FACTORY PARAMETERS TABLE

Menu	Parameter	Description	Unit of measure	Default Value	Set Value
St--	St01	Set-point setting % relative humidity, absolute humidity, DewPoint (Function excluded with parameter CF05 = 0)	% g/Kg °C	20,0	
	St02	Differential % relative humidity, absolute humidity, DewPoint (the differential works all over one side, above the set-point for dehumidification and below for humidification)	% g/Kg °C	5,0	
	St03	Neutral zone % relative humidity, absolute humidity, DewPoint (the neutral zone works at the center of the set-point split halfway up and down)	% g/Kg °C	0,0	
	St04	Set-point pre-treatment temperature setting (Function excluded with parameter CF08 = 0)	°C	10,0	
	St05	Differential pre-treatment temperature (the differential works all over one side, above the set-point for cooling and below for heating)	°C	2,0	
	St06	Neutral temperature pre-treatment temperature (the neutral zone works at the center of the set-point split halfway up and down)	°C	0,0	
	St08	Post-treatment temperature set-point setting (Function excluded with parameter CF09 = 0)	°C	200,0	
	St09	Differential temperature post-treatment (the differential works all over one side, above the set-point for cooling and below for heating)	°C	2,0	
	St010	Neutral temperature post-treatment temperature (the neutral zone works at the center of the set-point split halfway up and down)	°C	0,0	
	FA--	FA01...14	Factory settings (only on request)		
rC--	rC01...rC14	Factory settings (only on request)			
CF--	CF01...CF44	Factory settings (only on request)			
Hr--	Hr01...Hr04	Factory settings (only on request)			
CC--	CC01...CC06	Factory settings (only on request)			

Software Version 2.0.0

(*) To make the change take effect, it is necessary to boot the instrument, remove the power, wait for a few seconds and reset the voltage.

Alarm Menu.

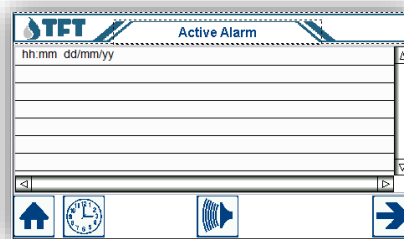
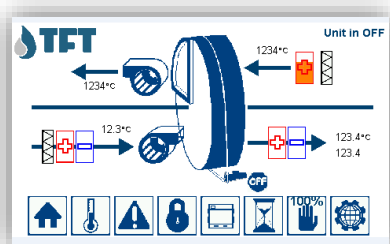

Scroll through the pages with the arrow keys to display the various pages. Press the key to set the correct system date and time. Press the key to reset active alarms. To return to the main menu, press the key .

ALARMS TABLE

ITEM	Description	Action	Reset
Process Fan Fault	Thermal process fan alarm	Deactivating the unit	Manual
Reactivation Fan Fault	Thermal rigeration fan alarm	Deactivating the unit	Manual
Motordrive Fault	Thermal alarm motor drive	Deactivating the unit	Manual
Heaters React. Fault	Thermal alarm regeneration heaters or burner alarm	Deactivating regeneration	Manual
Safety High Temp. React.	High temperature regeneration alarm from limit thermostat and / or safety	Deactivating regeneration	Manual
Rotor gear Fault	Rotor Stop alarm	Deactivating regeneration	Manual
Fault Probe Temp.React.	Regeneration temperature probe error, failed or disconnected	Deactivating regeneration	Automatic
Fault Probe Temp.Wet Air	Wei air Temperature probe error, failed or disconnected	Deactivating regeneration	Automatic
Fault Probe Temp.Pre-treatment	Pre-treatment temperature probe error, failed or disconnected	Deactivation of pre-treatment	Automatic
Fault Probe Temp.Post-treatment	Post-treatment temperature probe error, failed or disconnected	Deactivation of post-treatment	Automatic
Fault Probe Humidity	Humidity sensor error, failed or disconnected	Deactivating regeneration	Automatic
Fault Probe Process Air Flow	Error Probe Speed or Flow Fan Fan Process, failed or disconnected	No action	Automatic
High Temp. Output Wet Air	High temperature alarm output wet air	Deactivating regeneration	Automatic
Fault Probe React. Air Flow	Speed or air flow sensor error regeneration fan, failed or disconnected	No action	Automatic
Fault Input remote set Humidity	External set-point signal error humidity, missing or disconnected	No action	Automatic
Fault Input remote set Temp.	External set-point signal error post-treatment temperature, missing or disconnected	No action	Automatic
Heaters pre-heating Fault	Thermal alarm pre-heating heaters (if present)	Deactivation of pre-treatment	Manual
Heaters post-heating Fault	Thermal alarm post-heating heaters (if present)	Deactivation of post-treatment	Manual
Humidification Fault	General humidifier alarm (if present)	Deactivating humidification	Manual
Error configuration ER01	Configuration alarm: Pre-cooling / heating control has been enabled without having enabled the pre-treatment temperature probe (parameters CF30, CF31, CF08).	No action	Automatic
Error configuration ER02	Configuration alarm:	No action	Automatic

	Post-cooled / heated control has been enabled without having enabled the post-treatment temperature probe (parameters CF28, CF29, CF09).		
Error configuration ER03	Configuration alarm: Moisture control has been enabled without enabling the humidity probe (parameters CF32, CF05).	No action	Automatic
Error configuration ER04	Configuration alarm: The output 4 ... 20mA has been enabled with PWM control for regeneration, this output must be configured 0 ... 10V (parameters CF36, CF01).	No action	Automatic
Error configuration ER05			
Error configuration ER06	Configuration alarm: The calculated Dewpoint or Absolute Humidity was enabled without having enabled relative humidity and post-treatment probes (CF33, CF05, CF09).	No action	Automatic
Error configuration ER07	Configuration alarm: The air velocity or process air flow rate has been enabled without enabling the air velocity probe (FA03, FA04, CF13).	No action	Automatic
Error configuration ER08	Configuration alarm: The air flow display was enabled in Kg / h without having enabled the corresponding air, temperature and humidity air probes, and / or the various channel configuration parameters (FA03, FA04, CF13).	No action	Automatic

